

## W124 Diagnostic Trouble Codes (DTC) – Models with M119 Engine Only!

The pages in this document have the Diagnostic Trouble Codes (DTC's) for the following models:

**1990-1993 400E & 500E** (4.2L and 5.0L M119.97x engines)

**1994-1995 E420, E500, E60 AMG** (4.2L, 5.0L, & 6.0L M119.97x engines)

The chassis covered are:

**124.034** (Sedan with 4.2L M119.975 engine)

**124.036** (Sedan with 5.0L M119.974 engine)

**124.036** (Sedan with 6.0L M119.974 engine, option code 957, E60 AMG)

The diagnostic connector has 38 pins total, please see the next several pages which explain the specifics of each pin. Note that not all pins are used. Also, for the 400E / E420 (124.034), ASR traction control was optional. The DTC's are slightly different between models with ABS only (no ASR), and models with both ABS and ASR. Please make sure you are using the correct sheets when looking up codes for ABS/ ASR, and the EA/CC/ISC systems! All 500E / E500 / E60 models (124.036) came standard with both ABS and ASR.

- Models **without** ASR (124.034 only) have a CC/ISC (Cruise Control / Idle Speed Control) module, N4/3, which controls the CC/ISC actuator (M16/2). The ABS control module is N30.
- Models **with** ASR have an EA/CC/ISC (Electronic Accelerator / Cruise Control / Idle Speed Control) module, N4/1, which controls the EA/CC/ISC actuator (M16/1). The ABS/ASR control module is N30/1.

All systems have analog “blink codes” available, which can be read with the factory impulse counter tool, or a home-made “LED light box”. However, the digital 3-digit codes are more specific than the analog 1- or 2-digit codes, particularly for the E-GAS module (pin #7). To access digital 3-digit codes, a Mercedes digital scanner is required, such as the HHT (Hand Held Tester) or SDS (Star Diagnosis System); or an aftermarket digital scan tool (such as the Snap-On MT2500, Modis, or Solus; or Trisco Palm Scan). Some systems only have analog blink codes available (i.e., the ACC and SRS systems)... these systems do not offer any digital communication.

The Check Engine Light (CEL) may only be present on models with California emissions. Only these models will have a Diagnostic Module (DM). DM codes can be read using the built-in pushbutton & LED at the 8-pin connector in front of the CAN box, near the 38-pin connector. ONLY codes from the DM will show using the built-in LED, you cannot read codes from the LH, ABS, ASR, E-GAS, etc from this LED.

This document includes the complete list of DTC's for the following systems:

**Pin #4 – LH-SFI (LH Sequential Fuel Injection)**

(WIS Group 07.41, subgroup 3.1, section #11, five pages)

**Pin #6 - ABS (Anti-lock Brake System) - For models without ASR**

(WIS Group 42.30, subgroup 6.2, section #11, one page)

**Pin #6 - ABS / ASR (Anti-lock Brake System / ASR) - For models with ASR traction control**

(WIS Group 42.40, subgroup 5.2, section #12, two pages)

**Pin #7 - CC/ISC (Cruise Control / Idle Speed Control) - For models without ASR**

(WIS Group 30.21, subgroup 6.2, section #11, two pages) – aka “E-GAS Module”

**Pin #7 - EA/CC/ISC (Electronic Accelerator / CC / ISC) - For models with ASR traction control**

(WIS Group 30.20, subgroup 6.2, section #11, two pages) – aka “E-GAS Module”

**Pin #8 - Base Module (*Power supply for the other modules – has 4 fuses on top*) – aka “Basic Module”**

(WIS Group 54.21, subgroup 1.1, section #11, one page)

**Pin #16 - ACC (Automatic Climate Control) – *Only blink codes available***

(WIS Group 83.40, subgroup 0603, section B, four pages)

**Pin #17 - EZL (Digital Ignition System)**

(WIS Group 07.41, subgroup 5.2, section #11, two pages)

**Pin #19 - Diagnostic Module (*CA models only – will also have LED+pushbutton in front of CAN box*)**

(WIS Group 07.41, subgroup 8.1, section #11, one page)

**Pin #30 - Airbag / SRS (Supplemental Restraint System) - *Only blink codes available***

(WIS Group 91.60, subgroup 16.1, section 12, one page)

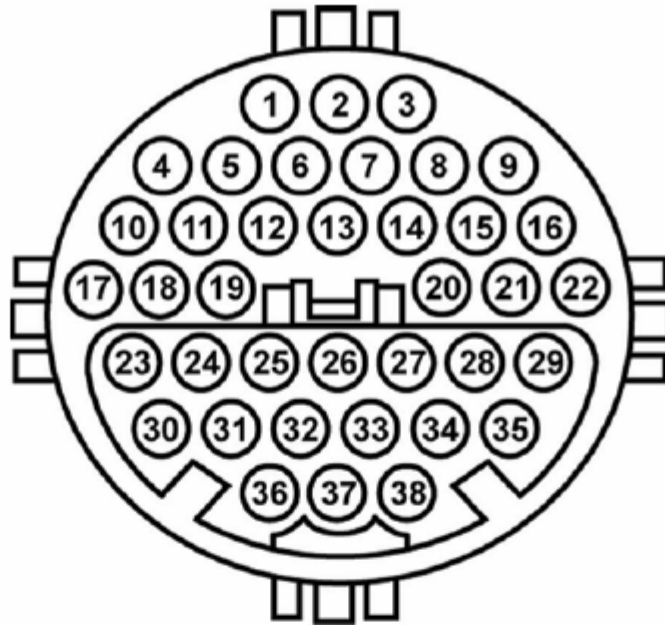

Figure 3-14 38-pin connector—fits MB-1 adapter

Table 3-2 38-pin connector pinout (sheet 1 of 2)

PIN	FUNCTION	PIN	FUNCTION
1	Ground, circuit 31 (W12, W15, electronics ground)	14	On-off ratio, engine 119 LH-SFI, engine 120 LH-SFI (right)
2	Voltage, circuit 87 or 15z	15	On-off ratio, engine 120 LH-SFI (left)
3	Voltage, circuit 30		Instrument cluster
4	Electronic diesel system	16	Air conditioning (models 124, 202, 208, 210)
	Electronic distributor-type fuel injection (diesel)		Tempmatic air conditioning (model 170)
	Electronic inline fuel injection (diesel)	17	Distributor ignition, engines 104, 119, engine 120 (right)
	HFM sequential multiport fuel injection/ignition		TD-speed signal (time division) (diesel) (model 140)
	LH sequential multiport fuel injection, engines 104, 119, 120 (right)		TN-speed signal, LH-SFI engines, HFM (model 202)
ME sequential multiport fuel injection/ignition, engines 119, 120 (right)	18	Distributor ignition, engine 120 (left)	
5	LH sequential multiport fuel injection, engine 120 (left)	19	Diagnostic module
	ME sequential multiport fuel injection/ignition, engine 120 (left)		20
6	Antilock brake system	21	
	Electronic traction system		Convenience feature (model 140)
	Acceleration slip regulation	Roadster soft top (model 129)	
	Electronic stability program	22	Roll bar (model 129)
7	Electronic accelerator	23	Anti-theft alarm
	Cruise control/idle speed control	24–25	Not used
8	Base module	26	Automatic locking differential (model 202)
	Brake assist	27	Not used

**Table 3-2** 38-pin connector pinout (sheet 2 of 2)

PIN	FUNCTION	PIN	FUNCTION
9	Automatic locking differential (models 124, 129, 140)	28	Parktronic system (model 140)
10	Electronic transmission control (A/T 5-speed)	29	Not used
	Electronic transmission control	30	Airbag/ETR (SRS)
11	Adaptive damping system	31	Remote central locking
12	Speed-sensitive power steering	32–33	Not used
13	TNA-signal (gasoline) LH-SFI engines	34	Communication and navigation system
	TD-signal (diesel) (model 210)	35–38	Not used
	TN-signal (gasoline), HFM (ME)-SFI engines		

## Diagnosis - Diagnostic Trouble Code (DTC) Memory

Preliminary work: ..... Engine Test and Adjustment, Engines, Volume 1

### On-Off Ratio Test

The on-off ratio tests the operation of the O2S (Lambda) control system and additionally, recognizes certain malfunctions present during the test.

Malfunctions are distinguished between those that occur with the **Ignition: ON** and those that occur with the **Engine: at CTP (idle)**.

The on-off ratio can be checked with the on-off ratio tester or with the engine analyzer. For this purpose, the purge line to the engine must be disconnected at the purge control valve and closed with a plug. Check on-off ratio at closed throttle speed and at 2500 rpm. A readout of 50% or an oscillating needle indicates that all input signals and the O2S control system are OK. Readouts of 10% to 90% or 95% refer to a particular malfunction source (see Malfunction Tables). In addition, after testing the on-off ratio, an impulse readout **must be performed** using the impulse counter scan tool.

### Diagnostic Trouble Code (DTC) Readout with Impulse Counter Scan Tool.

Malfunctions which occur while starting or with the engine running are recorded by a malfunction counter. Malfunctions are assigned a specific value according to malfunction severity (e.g. hot wire MAF sensor 128, ECT sensor 32). The malfunction counter counts in stages up to a threshold value of 255. After reaching the threshold value of 128, intermittent malfunctions are stored into memory after switching off the ignition. Malfunctions which affect engine operation ( $\geq 128$ ) are immediately stored into DTC memory by the malfunction counter after switching off the ignition.

## Diagnosis - Diagnostic Trouble Code (DTC) Memory

DTC's can be read with the impulse counter scan tool. Numbers ranging from 1 to 32 may appear on the display of the impulse counter scan tool.

The number 1 indicates: No DTC recognized in system.

All further numbers refer to a particular malfunction source. If there are multiple system malfunctions, the malfunction assigned with the lowest number will be displayed first.

If the DTC number indicated first reappears after more than two DTC readouts, then no further malfunctions are stored in the system's memory.

After eliminating all malfunctions, they must be **cleared individually and the ignition must be switched off for a minimum of 15 seconds**.

In case of engine running complaints, the DTC memory must be read and the malfunction must be eliminated before proceeding with any additional repairs.

### LH-SFI Control Module Self-Adaptation Feature

A self-adaptation feature for the emission control system is incorporated into the LH-SFI control module.

If malfunctions of the:

- Hot-wire MAF sensor,
- Injectors,
- Purge control valve,
- Diaphragm pressure regulator,
- Purge valve

occur or if intake air leaks are present, the LH-SFI control module conducts a self-adaptation process whereby the correction factors are continuously calculated and permanently stored.

## Diagnosis - Diagnostic Trouble Code (DTC) Memory

## LH Fuel Injection (Pin #4)

If a malfunction is no longer present during a subsequent engine start or engine operation, the total value recorded by the malfunction counter is reduced by 1 every time the engine is switched off. This procedure repeats itself until the malfunction counter is cleared.

Stored malfunctions (DTC's) can be read with the impulse counter scan tool at the data link connector (X11/4). (Also see DM, Engines, Volume 2, section 5.)



The DTC memory readout must be performed with the engine OFF and the ignition switched ON.

Malfunctions occurring in the following areas are stored immediately:

- CMP sensor,
- Hot-wire MAF sensor,
- Injectors.

A malfunction of the following is stored after more than 2 trips:

- TN-signal (input).

The memory remains active even if the vehicle's battery is disconnected.

After eliminating the mentioned malfunctions or after trial installation of a LH-SFI control module from another vehicle, the LH-SFI control module's self-adaptation feature must be reset to its mean value (see Resetting LH-SFI Control Module's Self-Adaptation Feature to Mean Value"  11/4 or with HHT menu selection 5 Self-Adaptation).

The LH-SFI control module will also adapt itself during the course of vehicle operation.

**Notes for HHT**

- Fault search with HHT.  
Diagnostic trouble code (DTC) memory: Select  "Current DTC's".  
If the actual condition changes, e.g. when wiggling a connector, the change is reported optically and acoustically so that troubleshooting can be performed directly with the HHT.
  
- Loose connections.  
Loose connections are stored if they occur several times in a certain time period. Therefore, they can appear only as  "Stored DTC's" and never as  "Current DTC's".
  
- Nominal values.  
All nominal values relative to the actual values as shown on the HHT are listed in the DM, Engines, Volume 1, section A.
  
- Actual values for ECT, IAT and MAF.  
In case of an open or short circuit, the actual value is immediately replaced by a substitute value which is very close to the actual value. Therefore, a fault can not be recognized clearly. A readout of the fault is possible only via the diagnostic trouble code (DTC) memory.
  
- Actual value for engine rpm.  
In case of the engine rpm's, the HHT display shows the closed throttle (idle) speed nominal value calculated by the control module on the left, and on the right, the rpm actual value. Both values should differ from each other only slightly. The permissible tolerances are not known.

**Diagnosis - Diagnostic Trouble Code (DTC) Memory**

**Preparation for Test with Impulse Counter Scan Tool**

- Connect impulse counter scan tool and on-off ratio tester according to connection diagram.
- **Reading Diagnostic Trouble Code (DTC) Memory**
  - a) Ignition: **ON**
  - b) Press start button for 2 to 4 seconds.
  - c) Read and record DTC readout.
  - d) Press start button again for 2 to 4 seconds.
  - e) Read and record DTC readout.

Repeat steps d) and e) until the first DTC reappears.

**Clearing Diagnostic Trouble Code (DTC) Memory**

- a) Press start button for 2 to 4 seconds (DTC readout appears).
  - b) Wait 3 seconds, press start button for 6 to 8 seconds, thereby clearing the previously displayed DTC from memory.
  - c) Each stored DTC must be cleared individually.
  - d) Ignition: **OFF** and wait 15 seconds.
- Check if all stored DTC's are eliminated.**
- e) Ignition: **ON**
  - f) Repeat DTC readout. The number  "!" (no DTC stored) must appear.

**Resetting LH-SFI Control Module's Self-Adaptation Feature to Mean Value**

After the number  "!" appears on the display, press start button for 6 to 8 seconds.  
Ignition: **OFF** and wait 30 seconds.

**Diagnosis - Diagnostic Trouble Code (DTC) Memory**

**Special Tools**

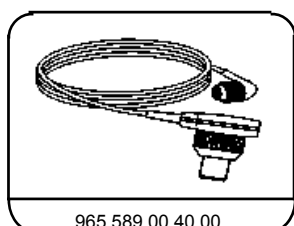
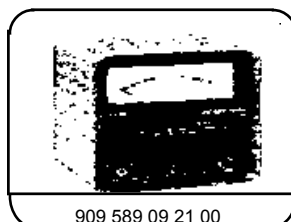
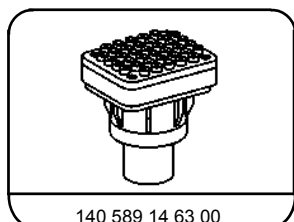
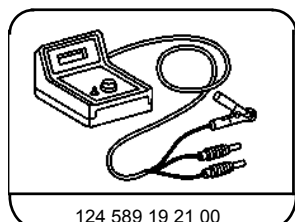

**Diagnosis - Diagnostic Trouble Code (DTC) Memory**

### Connection Diagram - Impulse Counter Scan Tool and On-Off Ratio Tester or Engine Analyzer with Diagnostic Socket X11

**Note:**

Connect red wire of impulse counter scan tool to socket 3, black wire of impulse counter scan tool to socket 1, yellow wire of impulse counter scan tool as follows:

- |                          |           |
|--------------------------|-----------|
| LH-SFI control module    | Socket 4  |
| DI control module        | Socket 17 |
| Base module              | Socket 8  |
| EA/CC/ISC control module | Socket 7  |
| Diagnostic module        | Socket 19 |

**LH Fuel Injection  
(Pin #4)**

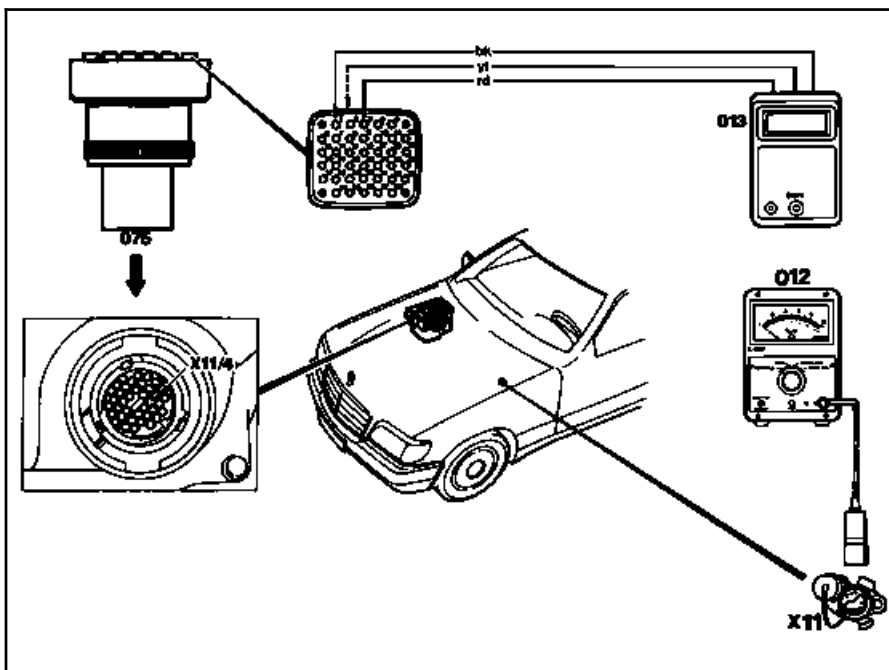

Figure 1

- |       |                                   |
|-------|-----------------------------------|
| 012   | On-off ratio tester               |
| 013   | Impulse counter scan tool         |
| 075   | Impulse counter scan tool adaptor |
| X11   | Diagnostic socket (9-pole)        |
| X11/4 | Data link connector (DTC readout) |

U07-5004-57

### Diagnosis - Diagnostic Trouble Code (DTC) Memory

#### Connection Diagram - Impulse Counter Scan Tool/ Hand-Held Tester and On-Off Ratio Tester without Diagnostic Socket X11

**Note:**

Connect red wire of impulse counter scan tool to socket 3, black wire of impulse counter scan tool to socket 1, yellow wire of impulse counter scan tool as follows:

- |                          |           |
|--------------------------|-----------|
| LH-SFI control module    | Socket 4  |
| Base module              | Socket 8  |
| EA/CC/ISC control module | Socket 7  |
| Diagnostic module        | Socket 19 |
| RPM signal (TN output)   | Socket 13 |
| On-off ratio readout     | Socket 14 |
| Circuit 31               | Socket 1  |
| Circuit 30               | Socket 3  |

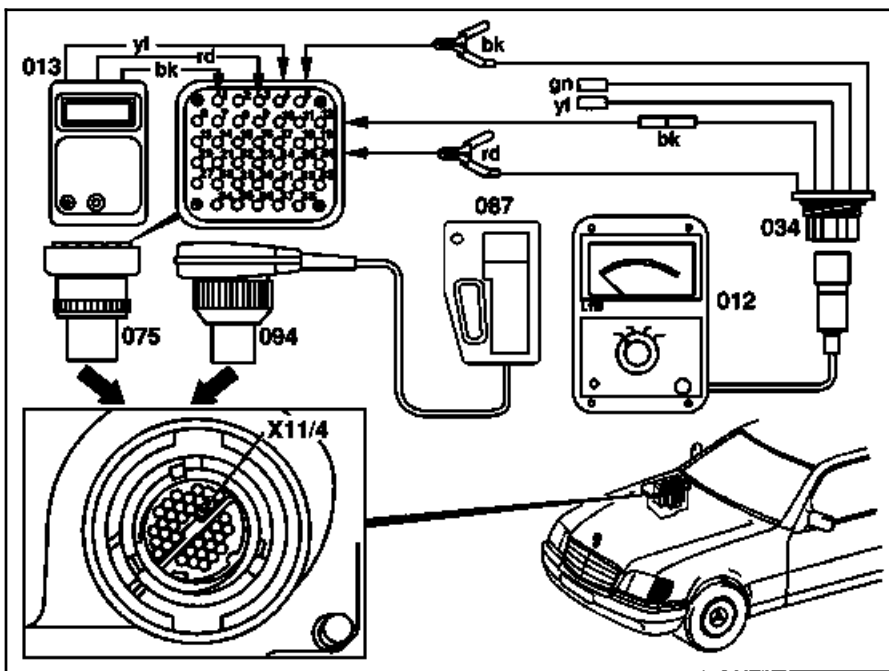

Figure 2

- |       |  |
|-------|--|
| 012   | On-off ratio tester  |
| 013   | Impulse counter scan tool                                  |
| 034   | Test cable   |
|       | Red alligator clip to socket 3                             |
|       | Black alligator clip to socket 1                           |
|       | Black male plug to socket 14                               |
|       | Green male plug not connected                              |
|       | Yellow male plug not connected                             |
| 075   | Impulse counter scan tool adaptor                          |
| 087   | Hand-Held Tester (optional with impulse counter scan tool) |
| 094   | Multiplex cable  |
| X11/4 | Data link connector (DTC readout)                          |

U07-6491-57

### Diagnosis - Diagnostic Trouble Code (DTC) Memory

**a) On-Off Ratio Test, Ignition: ON**

On-Off Ratio %	Possible cause	Test step/Remedy <sup>1)</sup>
00	Voltage supply from socket 3 of data link connector (X11/4) open circuit	Repair harness
10	CTP (idle) recognition inactive	□ 23 ⇒ 15.0
20	WOT (full load) recognition active	□ 23 ⇒ 15.0
30	Engine coolant temperature < 70 °C or >110 °C	□ 23 ⇒ 9.0, 10.0
40	Not used	
50	Input signals OK	
60	TN-signal (rpm signal) or CMP sensor signal not present while starting	□ 23 ⇒ 12.0 - 14.0
70	Starter engaged	□ 23 ⇒ 8.1
80	CAN-data exchange defective	□ 23 ⇒ 39.0

90	Fuel safety shut-off active	Check CC/ISC (see DM, Engines, Volume 3, Section 7.1) or Check EA (see DM, Engines, Volume 3, Section 6.2)
----	-----------------------------	--

1) Observe Preparation for Test, see □ 22.

## Diagnosis - Diagnostic Trouble Code (DTC) Memory

**LH Fuel Injection  
(Pin #4)**

### b) On-Off Ratio Test, Engine: at CTP (idle)

On-Off Ratio %	Possible cause	Test step/Remedy <sup>1)</sup>
0	Short circuit to battery + in wire to data link connector (X11/4), socket 3	Repair harness
10	CTP (idle) recognition applied constantly	□ 23 ⇒ 15.0
20	Output of fuel injectors or one or more fuel injectors have open circuit	□ 23 ⇒ 32.0, 33.0
30	ECT sensor (B11/2)	□ 23 ⇒ 9.0, 10.1
40	Hot wire MAF sensor (B2/2)	□ 23 ⇒ 5.0, 6.0
50 <sup>2)</sup>	O2S 1 (before TWC) (G3/2) not operational or defective, open circuit	□ 23 ⇒ 18.0 - 19.1
60	CMP sensor (L5/1)	□ 23 ⇒ 14.0
70	TN-signal (rpm signal)	□ 23 ⇒ 12.0, 13.0
80	CAN-data exchange defective	□ 23 ⇒ 39.0 - 40.0 Either EA/CC/ISC control module, CC/ISC control module or DI control module not transmitting.

1) Observe Preparation for Test, see □ 22.

2) Needle oscillates if all monitored signals are OK.

## Diagnosis - Diagnostic Trouble Code (DTC) Memory

### b) On-Off Ratio Test, Engine: at CTP (idle)

On-off Ratio %	Possible cause	Test step/Remedy <sup>1)</sup>
90	Vehicle speed signal (VSS)	Check CC/ISC (see DM, Engines, Volume 3, section 7.1) or Check EA (see DM, Engines, Volume 3, section 6.2)
95	Deceleration shut-off active	Check CC/ISC (see DM, Engines, Volume 3, section 7.1) or Check EA (see DM, Engines, Volume 3, section 6.2)
100	No voltage at LH-SFI control module (N3/1)	□ 23 ⇒ 1.0 - 3.0

1) Observe Preparation for Test, see □ 22.

## Diagnosis - Diagnostic Trouble Code (DTC) Memory

### c) LH-SFI Control Module DTC Readout

DTC	Possible cause	Test step/Remedy <sup>1)</sup>
P0001	No malfunction in system	-
P0112	ECT sensor (B11/2) sensor circuit 1, open/short circuit	□ 23 ⇒ 9.0
P0113	ECT sensor (B11/2) sensor circuit 2, open/short circuit	□ 23 ⇒ 10.0
P0130 <sup>2)</sup>	Voltage at hot wire MAF sensor (B2/2) insufficient or too high, or open circuit in ground wire at hot wire MAF sensor	□ 23 ⇒ 5.0 - 6.0
P0131	Not used	-
P0132	Not used	-
P0335	TN-signal (rpm signal) incorrect or open/short circuit	□ 23 ⇒ 12.0
P0340	CMP sensor (L5/1) signal, open/short circuit	□ 23 ⇒ 14.0
P0341	Starter signal (circuit 50) missing, open/short circuit	□ 23 ⇒ 8.1
P0450 <sup>3)</sup>	CTP (idle) recognition from EA/CC/ISC control module (N4/1) or CC/ISC control module (N4/3), short circuit	□ 23 ⇒ 15.0
P0451 <sup>4)</sup>	Secondary air injection system, open/short circuit	□ 23 ⇒ 23.0

1) Observe Preparation for Test, see □ 22.

2) DTC P0130 can be displayed on vehicles up to 7/91 even if no fault is present.

3) DTC P0450 can be displayed on vehicles up to 7/91 even if no fault is present.

4) DTC P0451 can be displayed on vehicles up to 7/91 even if no fault is present.

## Diagnosis - Diagnostic Trouble Code (DTC) Memory

### c) LH-SFI Control Module DTC Readout

DTC	Possible cause	Test step/Remedy <sup>1)</sup>
P0001	No malfunction in system	-

12	Burn-off control for hot wire MAF sensor, open/short circuit	□ 23 ⇒ 7.0
13	IAT sensor (B17/7), open/short circuit	□ 23 ⇒ 11.0
14	Not used	-
15	Not used	-
16 <sup>5)</sup>	EGR switchover valve (Y27), open/short circuit	□ 23 ⇒ 20.0
17 <sup>7)</sup>	No CAN data transmission with EA/CC/ISC control module (N4/1) or CC/ISC control module (N4/3)	□ 23 ⇒ 39.0 or N4/1 or N4/3.
18 <sup>6)</sup>	No CAN data transmission with DI control module (N1/3)	□ 23 ⇒ 39.0 or N1/3.
19	Not used	-
20	No CAN data transmission from LH-SFI control module (N3/1)	□ 23 ⇒ 40.0
21	O2S 1 (before TWC) (G3/2), open/short circuit	□ 23 ⇒ 18.0

1) Observe Preparation for Test, see □ 22.

5) DTC 16 can be displayed on vehicles up to 7/91 even if no fault is present.

6) DTC 18 can be displayed on vehicles up to 7/91 even if no fault is present.

7) DTC 17 can be displayed even if no fault is present.

**LH Fuel Injection  
(Pin #4)**

## Diagnosis - Diagnostic Trouble Code (DTC) Memory

### c) LH-SFI Control Module DTC Readout

DTC 	Possible cause	Test step/Remedy <sup>1)</sup>
22	O2S 1 heater, open/short circuit	□ 23 ⇒ 19.0
23	Purge control valve (Y58/1), open/short circuit	□ 23 ⇒ 24.0
24 <b>(Engine 119 only)</b>	Left adjustable camshaft timing solenoid (Y49/1), open/short circuit	□ 23 ⇒ 27.0
25	Adjustable camshaft timing solenoid, engine 104 (Y49) or right adjustable timing solenoid, engine 119 (Y49/2), open/short circuit	□ 23 ⇒ 26.0
26	Upshift delay switchover valve (Y3/3), open/short circuit	□ 23 ⇒ 34.0
27	Injectors (Y62), open/short circuit	□ 23 ⇒ 32.0
28	LH-SFI control module coding, open circuit	□ 23 ⇒ 43.0
29 <b>(Model 124.034 only)</b>	1GR start relay module (K29/1), open/short circuit	□ 23 ⇒ 44.0

1) Observe Preparation for Test, see □ 22.

## Diagnosis - Diagnostic Trouble Code (DTC) Memory

### Test Preparation for DTC Readout

1. Connect impulse counter scan tool or Hand-Held Tester to data link connector (X11/4) as shown in section 0.

#### Note:

Connect yellow wire from impulse counter scan tool as follows:  
 ABS control module (N30) socket 6  
 Base module (N16/1) socket 8

2. Ignition: **ON**.

3. Read DTC memory of ABS control module (N30), and base module (N16/1).

**ABS Only**  
*For models without ASR*  
 (Pin #6)

### Special Tools

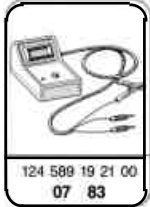

### Equipment

Hand-Held Tester (HHT)

see applicable Service Information in groups 58 and 99

## Diagnosis - Diagnostic Trouble Code (DTC) Memory

Diagnostic trouble code (DTC)	Possible cause	Test step/Remedy <sup>1)</sup>
1	No faults recognized. In case of complaint:	<input type="checkbox"/> 23 (entire test)
2	Left front axle vehicle speed sensor (L6/1), open circuit	<input type="checkbox"/> 23 ⇒ 10.0
3	Right front axle vehicle speed sensor (L6/2), open circuit	<input type="checkbox"/> 23 ⇒ 12.0
4	Rear axle vehicle speed sensor (L6), open circuit	<input type="checkbox"/> 23 ⇒ 14.0
5	Left front axle solenoid valve (A7y1)	<input type="checkbox"/> 23 ⇒ 16.0
7	Right front axle solenoid valve (A7y2)	<input type="checkbox"/> 23 ⇒ 17.0
8	Rear axle solenoid valve (A7y3)	<input type="checkbox"/> 23 ⇒ 18.0
10	Return pump (A7m1) or return pump relay (A7k2)	<input type="checkbox"/> 23 ⇒ 6.0
11	Solenoid valve relay (A7k1)	<input type="checkbox"/> 23 ⇒ 5.0
12	<b>Models 140.04/05:</b> Master cylinder switchover valve (Y61)	<input type="checkbox"/> 23 ⇒ 7.0
13	Brake lamp switch (S9/1)	<input type="checkbox"/> 23 ⇒ 9.0
14	<b>Models 140.04/05:</b> Lateral acceleration sensor (B24/2)	<input type="checkbox"/> 23 ⇒ 8.0
15	ABS control module (N30)	N30

<sup>1)</sup> Observe Preparation for Test, see  22.

## Diagnosis - Diagnostic Trouble Code (DTC) Memory

Diagnostic trouble code (DTC)	Possible cause	Test step/Remedy <sup>1)</sup>
16	Vehicle speed sensors (L6, L6/1, L6/2), implausible signal <sup>2)</sup>	<input type="checkbox"/> 23 ⇒ 10.0 <input type="checkbox"/> 23 ⇒ 12.0 <input type="checkbox"/> 23 ⇒ 14.0 Visual inspection
17	Solenoid valve relay (A7k1)	<input type="checkbox"/> 23 ⇒ 5.0
25	Left front axle vehicle speed sensor (L6/1), implausible signal <sup>2)</sup>	<input type="checkbox"/> 23 ⇒ 10.0
26	Right front axle vehicle speed sensor (L6/2), implausible signal <sup>2)</sup>	<input type="checkbox"/> 23 ⇒ 12.0
27	Rear axle vehicle speed sensor (L6), implausible signal <sup>2)</sup>	<input type="checkbox"/> 23 ⇒ 14.0
29	<b>Models 140.04/05:</b> Lateral acceleration sensor (B24/2), implausible signal	<input type="checkbox"/> 23 ⇒ 8.0

<sup>1)</sup> Observe Preparation for Test, see  22.

<sup>2)</sup> Incorrect number of rotor teeth, dirty or damaged, incorrect rear axle ratio, tires or wheels.

## Diagnosis - Diagnostic Trouble Code (DTC) Memory

**ABS + ASR**  
 For models with ASR  
 (Pin #6)

### Preparation for DTC Readout

1. Connect impulse counter scan tool or Hand-Held Tester (HHT) to data link connector (X11/4) according to connection diagram (see section 0).

#### Note:

Connect yellow wire from impulse counter scan tool to:

ABS/ASR control module (N30/1)	socket 6
BM (N16/1)	socket 8
SPS control module (N49/1)	socket 12
ADS control module (N51)	socket 11
TCM (N15/1)	socket 10
EA/CC/ISC control module (N4/1)	socket 7

Engine (N3/4), LH-SFI (N3/1) or Right LH-SFI control module (N3/3)	socket 4
Left LH-SFI control module (N3/2)	socket 5
DI (N1/3) or Right DI control module (N1/5)	socket 17
Left DI control module (N1/4)	socket 18

2. Ignition: **ON**
3. Read out DTC's for control modules listed.

### Special Tools



### Equipment

Hand-Held Tester (HHT)

See S.I. in groups 58 and 99.

## Diagnosis - Diagnostic Trouble Code (DTC) Memory

Diagnostic trouble code (DTC)	Possible cause	Test step/Remedy <sup>1)</sup>
1 —	No fault in system.	In case of complaint: <input type="checkbox"/> 23 and <input type="checkbox"/> 33 (entire test)
2 002	Left front axle VSS sensor (L6/1), open circuit	<input type="checkbox"/> 23 ⇒ 14.0
3 003	Right front axle VSS sensor (L6/2), open circuit	<input type="checkbox"/> 23 ⇒ 16.0
4 004	Left rear axle VSS sensor (L6/3), open circuit	<input type="checkbox"/> 23 ⇒ 18.0
5 005	Right rear axle VSS sensor (L6/4), open circuit	<input type="checkbox"/> 23 ⇒ 20.0
6 006	ABS/ASR hydraulic unit, left front axle solenoid valve (A7/3y1)	<input type="checkbox"/> 23 ⇒ 23.0
7 007	ABS/ASR hydraulic unit, right front axle solenoid valve (A7/3y2)	<input type="checkbox"/> 23 ⇒ 24.0
8 008	ABS/ASR hydraulic unit, left rear axle solenoid valve (A7/3y3)	<input type="checkbox"/> 23 ⇒ 25.0
9 009	ABS/ASR hydraulic unit, right rear axle solenoid valve (A7/3y4)	<input type="checkbox"/> 23 ⇒ 26.0
10 010	ABS/ASR hydraulic unit, high-pressure/return pump relay (A7/3k2), ABS/ASR hydraulic unit, high-pressure/return pump (A7/3m1)	<input type="checkbox"/> 23 ⇒ 8.0 <input type="checkbox"/> 23 ⇒ 2.0
11 011	ABS/ASR hydraulic unit, solenoid valve relay (A7/3k1)	<input type="checkbox"/> 23 ⇒ 7.0
<b>Models 124.036 (02/92 →), 129.076, 140.04/05/07</b>		
12 012	Master brake cylinder switchover valve (Y61)	<input type="checkbox"/> 23 ⇒ 9.0
13 013	Stop lamp switch (S9/1)	<input type="checkbox"/> 23 ⇒ 10.0

<sup>1)</sup> Observe Preparation for Test, see  22.

## Diagnosis - Diagnostic Trouble Code (DTC) Memory

Diagnostic trouble code (DTC)	Possible cause	Test step/Remedy <sup>1)</sup>
<b>Model 124.036 (02/93 →), 129.076, 140.04/04/07</b>		
14 014	ABS lateral acceleration sensor (B24/2), open circuit	<input type="checkbox"/> 23 ⇒ 13.0
15 015	ABS/ASR control module (N30/1)	Replace N30/1
16 016	Vehicle speed signal (VSS) (L6/1, L6/2, L6/3, L6/4), implausible <sup>2) 3)</sup>	<input type="checkbox"/> 23 ⇒ 14.0 <input type="checkbox"/> 23 ⇒ 16.0 <input type="checkbox"/> 23 ⇒ 18.0 <input type="checkbox"/> 23 ⇒ 20.0 Visually inspect
17 017	Battery voltage too low	<input type="checkbox"/> 23 ⇒ 1.0
20 020	ABS/ASR hydraulic unit, switchover/solenoid valve (A7/3y5)	<input type="checkbox"/> 23 ⇒ 27.0
21 021	ABS/ASR hydraulic unit, pressure switch (A7/3s1), charge	<input type="checkbox"/> 23 ⇒ 1.0, 2.0 <input type="checkbox"/> 23 ⇒ 22.0
22 022	ABS/ASR hydraulic unit, pressure switch (A7/3s1), leakage	<input type="checkbox"/> 23 ⇒ 1.0, 2.0 <input type="checkbox"/> 23 ⇒ 22.0
23 023	ABS/ASR hydraulic unit, pressure switch (A7/3s1), hydraulic	<input type="checkbox"/> 23 ⇒ 1.0, 2.0 <input type="checkbox"/> 23 ⇒ 22.0

<sup>1)</sup> Observe Preparation for Test, see  22.

<sup>2)</sup> Rotor with incorrect tooth count, dirt accumulation on or damaged rotor, incorrect rear axle ratio, wrong wheel or tire size.

<sup>3)</sup> If DTC appears only after repair work, it was caused by applying the brakes or driving vehicle on a dynamometer, erase DTC.

## Diagnosis - Diagnostic Trouble Code (DTC) Memory

Diagnostic trouble code (DTC)	Possible cause	Test step/Remedy <sup>1)</sup>
24 024	ASR charging pump (M15)	Wiring, <input type="checkbox"/> 33⇒ 1.0, 2.0
25 025	Left front axle VSS sensor (L6/1), implausible <sup>2)</sup>	<input type="checkbox"/> 23⇒ 14.0 Visually inspect.
26 026	Right front axle VSS sensor (L6/2), implausible <sup>2)</sup>	<input type="checkbox"/> 23⇒ 16.0 Visually inspect.
27 027	Left rear axle VSS sensor (L6/3), implausible <sup>2)</sup>	<input type="checkbox"/> 23⇒ 18.0 Visually inspect.
28 028	Right rear axle VSS sensor (L6/4), implausible <sup>2)</sup>	<input type="checkbox"/> 23⇒ 20.0 Visually inspect.
<b>Model 124.036 (02/93 →), 129.076, 140.04/04/07</b>		
29 029	ABS lateral acceleration sensor (B24/2), implausible	<input type="checkbox"/> 23⇒ 13.0
30 030	CAN data bus to EA/CC/ISC control module (N4/1), interrupted	<input type="checkbox"/> 23⇒ 28.0 Read out DTC for N4/1: see DM, Engines, Vol. 2, sections 6.2 or 6.3 <input type="checkbox"/> 11

<sup>1)</sup> Observe Preparation for Test, see  22.

<sup>2)</sup> Rotor with incorrect tooth count, dirt accumulation on or damaged rotor, incorrect rear axle ratio, wrong wheel or tire size.

**ABS + ASR**  
*For models with ASR*  
**(Pin #6)**

## Diagnosis - Diagnostic Trouble Code (DTC) Memory

Diagnostic trouble code (DTC)	Possible cause	Test step/Remedy <sup>1)</sup>
31 031	CAN data bus to LH-SFI control module (N3/1), Left LH-SFI control module (N3/2), Right LH-SFI control module (N3/3), or Engine control module (N 3/4), interrupted	<input type="checkbox"/> 23⇒ 28.0 Read out DTC for N3/1, N3/2, N3/3, N3/4: see DM, Engines, Vol. 2, sections 1.1, 3.1 or 3.2 <input type="checkbox"/> 11
32 032	CAN data bus to DI control module (N1/3), Left DI control module (N1/4), Right DI control module (N1/5), interrupted	<input type="checkbox"/> 23⇒ 28.0 Read out DTC for N1/3, N1/4, N1/5: see DM, Engines, Vol. 2 sections 5.2 or 5.3 <input type="checkbox"/> 11
33 033	CAN data bus, interrupted	<input type="checkbox"/> 23⇒ 28.0 Read out DTC for N4/1: see DM, Engines, Vol. 2, sections 6.2 or 6.3 <input type="checkbox"/> 11 Read out DTC for N1/3, N1/4, N1/5: see DM, Engines, Vol. 2 sections 5.2 or 5.3 <input type="checkbox"/> 11 Read out DTC for N3/1, N3/2, N3/3, N3/4: see DM, Engines, Vol. 2, sections 1.1, 3.1 or 3.2 <input type="checkbox"/> 11 Read out DTC for N15/1: see DM, Chassis & Drivetrain, Vol. 1 section 2.2 <input type="checkbox"/> 12

<sup>1)</sup> Observe Preparation for Test, see  22.

## Diagnosis - Diagnostic Trouble Code (DTC) Readout

**CC / ISC only**  
**For models without ASR**  
**(Pin #7)**

### Preparation for DTC Readout

- Connect impulse counter scan tool and/or HHT to data link connector (X11/4) according to connection diagram (see section 0).  
yellow wire to socket 7

### Special Tools

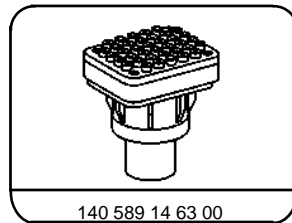
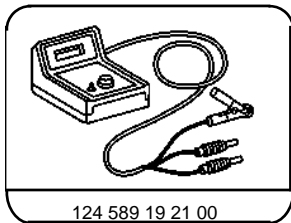

### Equipment

Hand-Held Tester (HHT) see current MBNA service information in groups 58 and 99

<sup>†)</sup> Available through the MBNA Standard Equipment Program.

## Diagnosis - Diagnostic Trouble Code (DTC) Readout

Diagnostic trouble code (DTC)	Possible cause	Test step/Remedy <sup>1)</sup>
1 -	No fault in system	-
2 002 006	CC/ISC control module (N4/3) Safety contact switch (M16/3s1) Stop lamp switch (S9/1)	N4/3 <input type="checkbox"/> 23 ⇒ 6.0-8.0 <input type="checkbox"/> 23 ⇒ 17.0 <input type="checkbox"/> 23 ⇒ 2.0
007	Cruise control switch (S40) OFF	N4/3 <input type="checkbox"/> 23 ⇒ 3.0, 5.0
008	CC/ISC control module (N4/3) Actual value potentiometer (M16/1r2) Starter lock-out/back-up lamp switch (S16/3) (transmission range recognition)	<input type="checkbox"/> 23 ⇒ 11.0 <input type="checkbox"/> 23 ⇒ 14.0 <input type="checkbox"/> 23 ⇒ 15.0, 16.0
009 025	Engine speed (TNA) signal Vehicle speed signal (VSS) Safety relay within CC/ISC control module (N4/3) CC/ISC control module (N4/3) Engine harness	N4/3 N4/3 Check harness wire insulation.
- 037	Conditions for activation of CC/ISC actuator (M16/2) not fulfilled.	Conditions: Engine: <b>OFF</b> Transmission range: <b>P/N</b>

<sup>†)</sup> Observe Preparation for Test, see  22.

## Diagnosis - Diagnostic Trouble Code (DTC) Readout

Diagnostic trouble code (DTC)	Possible cause	Test step/Remedy <sup>1)</sup>
3 054, 056 048 049 050 051 057 055	CC/ISC actuator (M16/2) Throttle valve actual value potentiometer (M16/2r2) Drive actual value potentiometer (M16/2r1) Safety contact switch (M16/2s1) Closed throttle recognition switch (M16/2s2) CC/ISC actuator (M16/2) (voltage supply) Reset not accomplished (actuator adaptation)	<input type="checkbox"/> 23 ⇒ 3.0-10.0 <input type="checkbox"/> 23 ⇒ 5.0 <input type="checkbox"/> 23 ⇒ 4.0 <input type="checkbox"/> 23 ⇒ 6.0, 8.0 <input type="checkbox"/> 23 ⇒ 6.0, 7.0 <input type="checkbox"/> 23 ⇒ 3.0 Erase DTC: Ignition: <b>OFF</b> Ignition: <b>ON</b> (for at least 90 seconds). If DTC reappears: CC/ISC actuator (M16/2)
4 064	Cruise control switch (S40)	<input type="checkbox"/> 23 ⇒ 2.0
5 080	Stop lamp switch (S9/1)	<input type="checkbox"/> 23 ⇒ 17.0
6 097	<b>Not valid for U.S.A. vehicles</b>	

<sup>†)</sup> Observe Preparation for Test, see  22.

## Diagnosis - Diagnostic Trouble Code (DTC) Readout

Diagnostic trouble code (DTC)	Possible cause	Test step/Remedy <sup>1)</sup>
7 112 115	<b>CAN databus:</b> Message from CC/ISC control module (N4/3) faulty Reception from LH-SFI control module (N3/1) faulty	N4/3 <input type="checkbox"/> 23 ⇒ 21.0
8 129, 130	Left front axle vehicle speed signal (L6/1) from ABS control module (N30)	<input type="checkbox"/> 23 ⇒ 15.0
9 144	Rear axle vehicle speed signal (L6) from ABS control module (N30)	<input type="checkbox"/> 23 ⇒ 16.0
10 160	Engine speed signal (TNA) from base module (N16/1)	<input type="checkbox"/> 23 ⇒ 14.0
11 176, 182 177-179	Fuel safety shut-off signal to LH-SFI control module (N3/1) Closed throttle recognition signal to LH-SFI control module (N3/1)	<input type="checkbox"/> 23 ⇒ 19.0 <input type="checkbox"/> 23 ⇒ 20.0

**CC / ISC only**  
*For models without ASR*  
**(Pin #7)**

## Diagnosis - Diagnostic Trouble Code (DTC) Readout

**EA / CC / ISC**  
**For models with ASR**  
**(Pin #7)**

### Preparation for DTC Readout

- Connect impulse counter scan tool and/or HHT to data link connector (X11/4) according to connection diagram.  
Yellow wire to socket 7

### Note

The Test Program is divided into two sections:

- Electronic accelerator with ISC
- Cruise control

According to the diagnosis made, troubleshoot by performing only the related test steps in the particular group.

### Special Tools

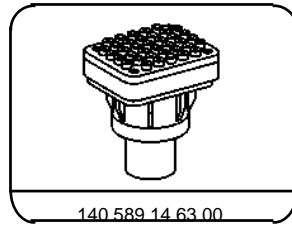
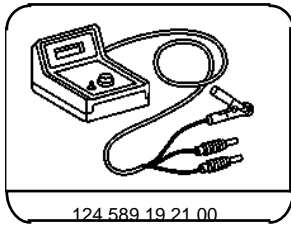

### Equipment

Hand-Held Tester (HHT)

see current MBNA service information in groups 58 and 99

## Diagnosis - Diagnostic Trouble Code (DTC) Readout

Diagnostic trouble code (DTC)	Possible cause	Test step/Remedy <sup>1)</sup>
1 -	No fault in system	-
2 002 006	EA/CC/ISC control module (N4/1) Safety contact switch (M16/1s1) Stop lamp switch (S9/1)	N4/1 <input type="checkbox"/> 23 ⇒ 5.0, 6.0 <input type="checkbox"/> 24 ⇒ 2.0, 3.0
007	Safety contact switch (M16/1s1) Cruise control switch (S40) OFF	<input type="checkbox"/> 23 ⇒ 5.0, 7.0 <input type="checkbox"/> 24 ⇒ 1.0
008	EA/CC/ISC control module (N4/1) Actual value potentiometer (M16/1r2)	N4/1 <input type="checkbox"/> 23 ⇒ 2.0, 4.0
009	Starter lock-out/back-up lamp switch (S16/3) (transmission range recognition)	<input type="checkbox"/> 23 ⇒ 12.0
025	Closed throttle position switch (S29/3) Engine speed (TNA) signal Vehicle speed signal (VSS)	<input type="checkbox"/> 23 ⇒ 11.0 <input type="checkbox"/> 23 ⇒ 15.0 <input type="checkbox"/> 23 ⇒ 16.0
- 037	Safety relay within EA/CC/ISC control module (N4/1) EA/CC/ISC control module (N4/1) Engine harness	N4/1 N4/1 Check harness wire insulation.
-	Conditions for activation of EA/CC/ISC actuator (M16/1) not fulfilled.	Conditions: Engine: <b>OFF</b> Transmission range: <b>P/N</b>

<sup>1)</sup> Observe Preparation for Test.

## Diagnosis - Diagnostic Trouble Code (DTC) Readout

Diagnostic trouble code (DTC)	Possible cause	Test step/Remedy <sup>1)</sup>
3 054, 056 048 049, 057 050 051	EA/CC/ISC actuator (M16/1) Reference potentiometer (M16/1r1) Actual value potentiometer (M16/1r2) Safety contact switch (M16/1s1) Closed throttle position switch (M16/1s2)	<input type="checkbox"/> 23 ⇒ 2.0-10.0 <input type="checkbox"/> 23 ⇒ 2.0, 3.0 <input type="checkbox"/> 23 ⇒ 2.0, 4.0 <input type="checkbox"/> 23 ⇒ 5.0, 7.0 <input type="checkbox"/> 23 ⇒ 5.0, 6.0
3 052	Actuator motor (M16/1m1)	<input type="checkbox"/> 23 ⇒ 9.0
3 053	Magnetic clutch (M16/1k1)	<input type="checkbox"/> 23 ⇒ 10.0
- 055	Reset not accomplished (actuator adaptation)	Erase DTCs: Ignition: <b>OFF</b> Ignition: <b>ON</b> (for at least 90 seconds). If DTC appears: EA/CC/ISC actuator (M16/1)
4 064	Cruise control switch (S40)	<input type="checkbox"/> 24 ⇒ 1.0
5 080	Stop lamp switch (S9/1)	<input type="checkbox"/> 24 ⇒ 2.0, 3.0
6 096	Starter lock-out/backup lamp switch (S16/1)	<input type="checkbox"/> 23 ⇒ 12.0
6 097	<b>Not valid for U.S.A. vehicles</b>	
7 112 113 115	<b>CAN databus:</b> Message from EA/CC/ISC control module (N4/1) faulty Message from ABS/ASR control module (N30/1) faulty Message from LH-SFI control module (N3/1) faulty	N4/1, <input type="checkbox"/> 23 ⇒ 20.0 <input type="checkbox"/> 23 ⇒ 20.0

<sup>1)</sup> Observe Preparation for Test.

## Diagnosis - Diagnostic Trouble Code (DTC) Readout

Diagnostic trouble code (DTC)	Possible cause	Test step/Remedy <sup>1)</sup>
8 128-130	Left front axle vehicle speed signal (L6/1) from ABS/ASR control module (N30/1)	□ 23⇒ 16.0
9 144	Left rear axle vehicle speed signal (L6/3) from ABS/ASR control module (N30/1)	□ 23⇒ 17.0
10 160	Engine speed signal (TNA) from base module (N16/1)	□ 23⇒ 15.0
11 176-188	Fuel safety shut-off signal to LH-SFI control module (N3/1)	□ 23⇒ 18.0
- 177-180	Closed throttle recognition signal to LH-SFI control module (N3/1)	□ 23⇒ 19.0
12 192, 193	Voltage supply, circuit 87	□ 23⇒ 1.0
14 224	Closed throttle position switch (S29/3)	□ 23⇒ 11.0
15 240	Data exchange with ABS/ASR control module (N30/1) implausible	N30/1

<sup>1)</sup> Observe Preparation for Test.

**EA / CC / ISC**  
*For models with ASR*  
 (Pin #7)

## Diagnosis - Diagnostic Trouble Code (DTC) Memory

**BM - Base Module  
(Pin #8)**

### CAUTION!

On vehicles with ME-SFI (for identification see: control module box), the base module (BM) (N16/1) is not equipped with DTC memory. DTC's can only be retrieved by performing the Electrical Test Program □ 23.

### Test Preparation for DTC Readout

1. Connect impulse counter scan tool and adapter or HHT to data link connector (X11/4) as shown in section 0.

#### Note:

Connect yellow wire from impulse counter scan tool as follows:

Base module (BM) (N16/1)	socket 8
ABS or ASR control module (N30 or N30/1) or ASR/SPS control module (N47-1) or ESP/SPS control module (N47-5)	socket 6
SPS control module (N49/1)	socket 12
ADS control module (N51)	socket 11
EDS control module (N39), LH-SFI or Right LH-SFI control module (N3/1 or N3/3), ME-SFI (Engine 119) or ME-SFI (Engine 120) right engine control module (N3/10, N3/12)	socket 4
Left LH-SFI control module (N3/2) or ME-SFI (Engine 120) left engine control module (N3/11)	socket 5

2. Ignition: **ON**
3. Read DTC memory (as applicable) for appropriately connected: BM, ABS or ASR, ASR/SPS, ESP/SPS, ME-SFI, ADS, LH-SFI control modules.

### Special Tools

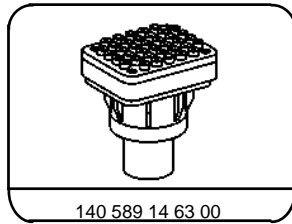
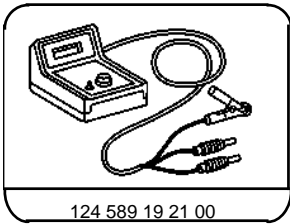

### Equipment

Description	
Hand-Held Tester (HHT)	see applicable Service Information in groups 58 and 99

1) Available through the MBNA Standard Equipment Program.

## Diagnosis - Diagnostic Trouble Code (DTC) Memory

DTC		Possible cause	Test step/Remedy <sup>1)</sup>
001	01	No fault in system.	In case of complaint: □ 23 (entire test)
005	05	Maximum allowable temperature in module box (F23) exceeded <sup>2)</sup> .	□ 23 ⇒ 19.0
006	06	A/C electromagnetic clutch (A9k1) jammed or poly-V-belt broken.	□ 23 ⇒ 15.0, visually inspect compressor and poly-V-belt
007	07	Poly-V-belt slips.	□ 23 ⇒ 15.0, check poly-V-belt tension
008	08	<b>Engine 120:</b> Left LH-SFI control module (N3/2) voltage supply, open circuit.	□ 23 ⇒ 4.0
009	09	<b>Engine 104, 119:</b> LH-SFI control module (N3/1) voltage supply, open circuit. <b>Engine 120:</b> Right LH-SFI control module (N3/3) voltage supply, open circuit.	□ 23 ⇒ 3.0
010	010	Base module (N16/1) voltage supply output fuse F2, open circuit.	□ 23 ⇒ 6.0, 8.0
011	011	Base module (N16/1) voltage supply output fuse F3, open circuit.	□ 23 ⇒ 11.0
012	012	Base module (N16/1) voltage supply output fuse F1, open circuit.	□ 23 ⇒ 10.0
013	013	Base module (N16/1) voltage supply output fuse F4, open circuit.	□ 23 ⇒ 5.0, 7.0
015	015	Kickdown switch (transmission mode) (S16/7), short circuit.	□ 23 ⇒ 20.0
016	016	A/C electromagnetic clutch (A9k1), short circuit.	□ 23 ⇒ 15.0
017	017	Module box blower motor (M2/2), short circuit <sup>2)</sup> .	□ 23 ⇒ 19.0

1) Observe Preparation for Test, see □ 22.

2) Module box blower motor was phased out of production on model 140 starting M.Y. 1994.

**B. All models 124 except models 124.034/036 as of 08/91**

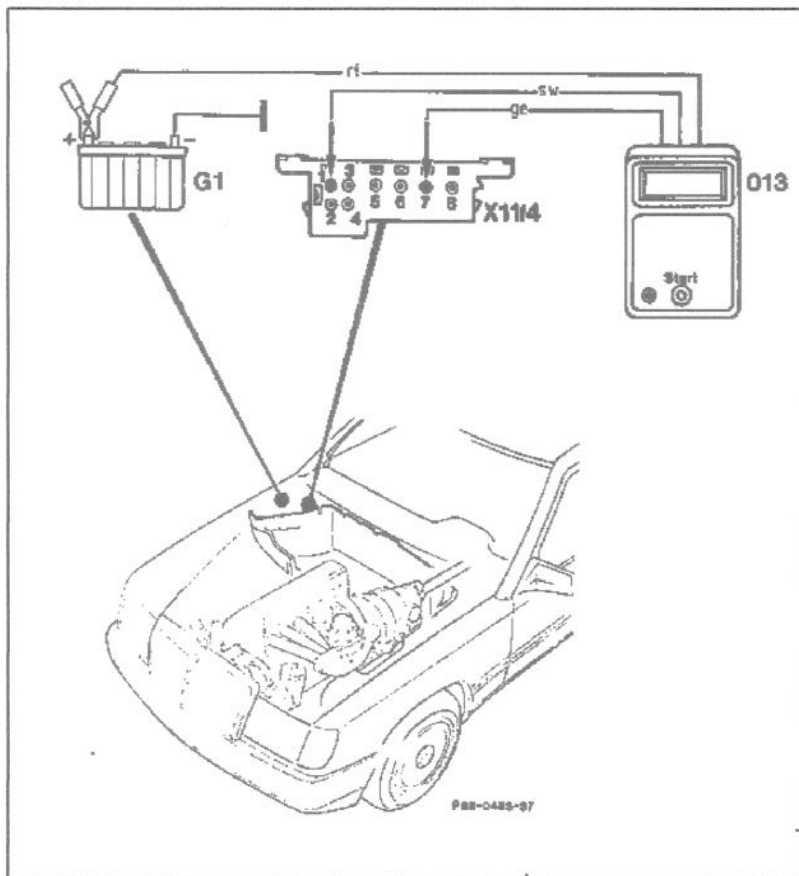

Connection diagram

013 Pulse counter  
G1 Battery  
X11/4 Test connector for diagnosis, 8-pin (pulse signal)

**The quantity of pulses indicates which component or which lines are defective**

Pulse readout	Components
1	All functions "in order"
2	In-car temperature sensor, short-circuit
3	In-car temperature sensor, interrupt
4	Outside air temperature sensor, short-circuit

Pulse readout	Components
5	Outside air temperature sensor, interrupt
6	Evaporator temperature sensor, short-circuit
7	Evaporator temperature sensor, interrupt
8	Left heat exchanger temperature sensor, short-circuit
9	Left heat exchanger temperature sensor, interrupt
10	Right heat exchanger temperature sensor, short-circuit
11	Right heat exchanger temperature sensor, interrupt

12	Coolant temperature sensor, short-circuit
13	Coolant temperature sensor, interrupt
30	Circulation pump, short-circuit/interrupt
31/32	Duo valve, short-circuit/interrupt
33	Compressor cut-out control unit, short-circuit/interrupt
34	Auxiliary fan 2nd stage (actuation), short-circuit
56	Valve block (4 connections) (Y11), short-circuit or interrupt
57	Valve block (4 connections) (Y11), short-circuit or interrupt
58	Valve block (4 connections) (Y11), short-circuit or interrupt

**ACC**  
**Automatic Climate Control**  
**(Pin #16)**

**Special tool**



### Notes on pulse output

The pulse output indicates existing faults, however faults which occur temporarily are not stored.

Testing with the pulse counter is to be performed for more rapid fault finding in the event of faults in the air conditioner/automatic temperature control.

If one or more faults are displayed by the pulse output, then these are to be eliminated and the pulse output to be repeated. This ensures that all faults which are recorded by the pulse output have been eliminated.

If no fault is displayed by the pulse output, but there is a complaint, it is possible that there is a tolerance deviation of components, e.g. too low ohmic value in the case of sensors. Since such a deviation is not recorded by the pulse output, the system is to be completely checked using the socket box and volt-ohmmeter.

ACC  
Automatic Climate Control  
(Pin #16)

### Testing

Connect pulse counter in accordance with the connection diagram.

"UBatt" light emitting diode must light up, if not:  
Switch on ignition.

- a) Check fuse
- b) Check socket 1 on test coupling (X11/4) versus battery positive. Nominal value 11-14 V.
- c) Check socket 1 against socket 7 on test coupling (X11/4). Nominal value 6-12 V.

Operate start button for between 2 and 4 seconds.

Read off and note pulse code display.

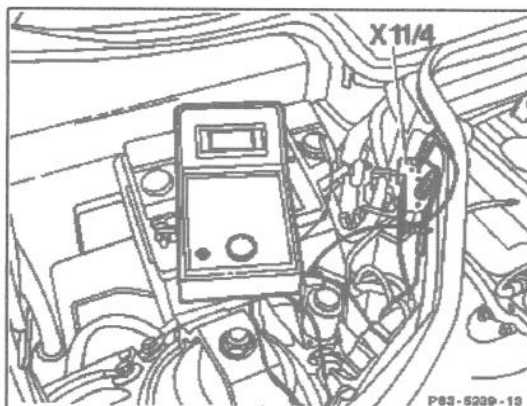

Number 1 means that no fault has been recorded by the pulse output. All further numbers are assigned to a particular fault circuit. If there are several faults in the system, the next fault is automatically output with the subsequent operation of the start button.

ACC  
Automatic Climate Control  
(Pin #16)

Operate the start button again for between 2 and 4 seconds. If there is no fault in the system, the first number re-appears.

Eliminate noted faults (pulse output) and repeat pulse output, and also switch the ignition on and off.

**Note**

During the pulse output the light emitting diode in the fresh air/recirculated air switch flashes with 1 Hz.

## Diagnosis - Diagnostic Trouble Code (DTC) Memory

**EZL / DI - Digital Ignition  
(Pin #17)**

### Diagnostic Trouble Code (DTC) Readout with Impulse Counter Scan Tool.

The DI control module (N1/3) is equipped with DTC readout including malfunction memory.

Malfunctions which occur with the engine running are counted by a malfunction counter. A malfunction is recorded into memory only if the same malfunction has occurred after 8 sequential engine starts.

This prevents a malfunction from being recorded if, for example, it occurred only once. If, for example, a malfunction occurred only 7 times, then the malfunction counter will be cleared again after a certain number of engine starts.

The memory remains active even if the vehicle's battery is disconnected.

Malfunctions occurring in the following areas are stored immediately:

- CKP sensor defective (diagnostic trouble code 17).
- Magnets for CKP sensor not recognized (diagnostic trouble code 18) (Engine 119 only).

## Diagnosis - Diagnostic Trouble Code (DTC) Memory

Preparation for Test with Impulse Counter Scan Tool

- Connect impulse counter scan tool according to connection diagram (see section 0).
- Read DTC memory (see section 0).

### Special Tools

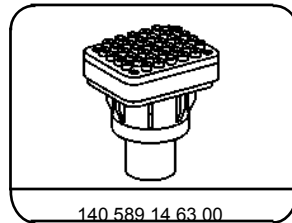
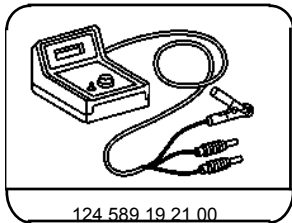

## Diagnosis - Diagnostic Trouble Code (DTC) Memory

DTC	Possible cause	Test step/Remedy <sup>1)</sup>
1	No malfunction in system	-
2	Maximum retard setting on at least one cylinder has been reached	Increased knock tendency, i.e. due to poor fuel quality, carbon build-up, mechanical damage.
3	Not used	-
4	MAP sensor in DI control module (N1/3) defective	Check vacuum supply to N1/3, Replace N1/3.
5	Knock sensor 1 and/or 2 defective	Knock sensor not plugged in at N1/3, Replace knock sensor.
6	CMP sensor (L5/1) defective	□ 24 ⇒ 1.0
7	Knock control-output switch in DI control module (N1/3) defective	Replace N1/3.
8	Transmission overload protection switch (S65) does not close	□ 24 ⇒ 5.0
9	Transmission overload protection switch (S65) does not open	□ 24 ⇒ 6.0
10	Not used	-
11	Reference resistor (DI) (R16/2) defective	□ 24 ⇒ 4.0
12	TN-signal (engine rpm output) is outside of tolerance range	□ 24 ⇒ 7.0
13	Not used	-

<sup>1)</sup> Observe Preparation for Test, see □ 22.

## Diagnosis - Diagnostic Trouble Code (DTC) Memory

DTC	Possible cause	Test step/Remedy <sup>1)</sup>
14	Not used	-
15	Ignition coil 1 output from DI control module (N1/3) defective or primary winding of ignition coil has open circuit	□ 23 ⇒ 7.0
16 119 only	Ignition coil 2 output from DI control module (N1/3) defective or primary winding of ignition coil has open circuit	□ 23 ⇒ 8.0
17	CKP sensor (L5) defective	□ 23 ⇒ 4.0
18 119 only	Magnets for CKP sensor (L5) not recognized	□ 23 ⇒ 5.0
19	Not used	-

20	DI control module (N1/3) DTC memory defective	Replace N1/3.
21	MAP sensor in DI control module (N1/3) defective (recognized with engine running)	Replace N1/3.
22	Not used	-
23	Not used	-
24	Not used	-
25	Not used	-
26	DI control module (N1/3) data exchange malfunction	<input type="checkbox"/> 24 ⇒ 8.0 - 9.0
27	LH-SFI control module (N3/1) data exchange malfunction	<input type="checkbox"/> 24 ⇒ 8.0
28	EA/CC/ISC control module (N4/1) data exchange malfunction	<input type="checkbox"/> 24 ⇒ 8.0

1) Observe Preparation for Test, see  22.

**EZL / DI - Digital Ignition  
(Pin #17)**

**Diagnosis - Diagnostic Trouble Code (DTC) Memory**

DTC	Possible cause	Test step/Remedy <sup>1)</sup>
29	Not used	-
30	Not used	-
31	Not used	-
32	Not used	-
33	Not used	-
34	Ignition misfire cylinder 1 (engine 104)      cyl. 1 (engine 119)	2)
35	Ignition misfire cylinder 5 (engine 104)      cyl. 5 (engine 119)	2)
36	Ignition misfire cylinder 3 (engine 104)      cyl. 4 (engine 119)	2)
37	Ignition misfire cylinder 6 (engine 104)      cyl. 8 (engine 119)	2)
38	Ignition misfire cylinder 2 (engine 104)      cyl. 6 (engine 119)	2)
39	Ignition misfire cylinder 4 (engine 104)      cyl. 3 (engine 119)	2)
40 <b>119 only</b>	Ignition misfire      cyl. 7 (engine 119)	2)
41 <b>119 only</b>	Ignition misfire      cyl. 2 (engine 119)	2)

1) Observe Preparation for Test, see  22.

2) Spark plugs, ignition wire of respective cylinder, high-voltage distributor     23 = Test steps 11.0 - 12.0, ignition coil     23 = Test steps 9.0 - 10.0, DI control module.

## Diagnosis - Diagnostic Trouble Code (DTC) Memory

### Preparation for recalling diagnostic trouble code (DTC) memory

1. Connect impulse counter scan tool and adaptor for impulse counter scan tool to diagnostic connector (X11/4) according to connection diagram (see section 0).

LH-SFI control module	socket	4
Ignition control module	socket	17
EA/CC/ISC control module	socket	7

#### Note:

Connect impulse counter scan tool as follows:

red wire to socket 3,  
black wire to socket 1 and  
yellow wire to:

Diagnostic module	socket	19
Base module	socket	8

2. Recall control modules' diagnostic trouble code memory and clear stored trouble codes (see section 0).

**DM - Diagnostic Module  
(Pin #19)**

### Special Tools

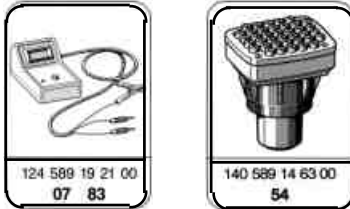

## Diagnosis - Diagnostic Trouble Code (DTC) Memory

### Diagnostic Trouble Code (DTC) Readout, Diagnostic Module

Diagnostic Trouble Code (DTC)	Possible Cause	Remedy/Test Step <sup>1)</sup>
<b>1</b>	No malfunction in systems monitored	-
<b>2</b>	Heated oxygen sensor inoperative	Test LH-SFI, section 3.1.
<b>3</b>	Lambda control inoperative	Test LH-SFI, section 3.1.
<b>4</b>	Air injection inoperative	Test LH-SFI, section 3.1.
<b>5</b>	Exhaust gas recirculation inoperative	Test LH-SFI, section 3.1.
<b>6</b>	Idle speed control inoperative	Test electronic accelerator, section 6.2.
<b>7</b>	Ignition system defective	Test distributor ignition system, section 5.2.
<b>8</b>	Engine coolant temperature sensor, open/short circuit	Test LH-SFI, section 3.1.
<b>9</b>	Intake air temperature sensor, open/short circuit	Test LH-SFI, section 3.1.
<b>10</b>	Voltage at mass air flow sensor too high/low	Test LH-SFI, section 3.1.
<b>11</b>	TN-signal (rpm) at LH-SFI control module (N3/1) defective	Test LH-SFI, section 3.1.
<b>12</b>	Heated oxygen sensor heater, open/short circuit	Test LH-SFI, section 3.1.
<b>13</b>	Camshaft position sensor signal of ignition control module defective.	Test LH-SFI, section 3.1.
<b>14</b>	Intake manifold pressure at start (in ignition control module - N1/3) too low/high	Vacuum supply to N1/3, test distributor ignition system, section 5.2.

<sup>1)</sup> Observe Preparation for Test, see □ 22.

## Diagnosis - Diagnostic Trouble Code (DTC) Memory

Diagnostic Trouble Code (DTC)	Possible Cause	Remedy/Test Step <sup>1)</sup>
<b>15</b>	Wide open throttle information defective	Test electronic accelerator, section 6.2.
<b>16</b>	Closed throttle position information defective	Test electronic accelerator, section 6.2.
<b>17</b>	Data exchange malfunction between individual control modules	□ 23 ⇒ 7.0.
<b>18</b>	Adjustable camshaft timing solenoid, open/short circuit	Test LH-SFI, section 3.1.
<b>19</b>	Fuel injectors open/short circuit or emission control system adaptation in LH-SFI control module (N3/1) at limit	Test LH-SFI and reset LH-SFI control module adaptation to mean value, section 3.1.
<b>20</b>	Speed signal not present	Test electronic accelerator, section 6.2.
<b>21</b>	Purge switchover valve, open/short circuit	Test LH-SFI, section 3.1.
<b>22</b>	Camshaft position sensor signal defective	Test distributor ignition system, section 5.2.
<b>23</b>	Intake manifold pressure (in ignition control module - N1/3) with engine running too low/high	Vacuum supply to N1/3, test distributor ignition system, section 5.2.
<b>24</b>	Starter ring gear segments and/or crankshaft position sensor defective	Test distributor ignition system, section 5.2.
<b>25</b>	Knock sensors or ignition control module defective	Test distributor ignition system, section 5.2.
<b>26</b>	Upshift delay switchover valve, open/short circuit	Test LH-SFI, section 3.1.
<b>27</b>	Engine coolant temperature sensor deviation between sensor circuit 1 and sensor circuit 2	Test LH-SFI, section 3.1.
<b>28</b>	Engine coolant temperature sensor (engine coolant temperature change monitor)	Test LH-SFI, section 3.1.

## Diagnosis - Diagnostic Trouble Code (DTC) Memory (driver-side or driver/passenger-side airbag)

Preliminary work:

Diagnosis - Function Test .....□ 11

**SRS - Airbag**  
**(Pin #30)**

### Preparation for DTC readout

- Fuses O.K.
- Connect impulse counter scan tool to data link connector (X11/4) according to connection diagram (see section 0).  
8 or 16-pole connector: yellow wire to socket 6  
38-pole connector: yellow wire to socket 30
- The 10-pole SRS test connection (X11/13) must be connected for DTC.

### Special Tools

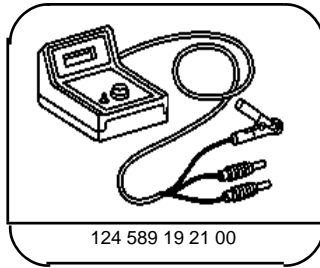

124 589 19 21 00

Pulse counter

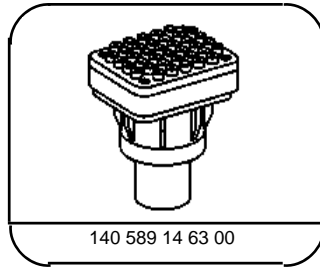

140 589 14 63 00

Adapter

## Diagnosis - Diagnostic Trouble Code (DTC) Memory (driver-side or driver/passenger-side airbag)

Diagnostic trouble code (DTC) □	Possible cause	Test step/Remedy <sup>1)</sup>
1	No fault recognized in system	-
2	SRS control module (N2/2)	□ 23 ⇒ 2.0
3	Driver airbag squib (R12/3)	□ 23 ⇒ 3.0, 9.0
4	Front passenger airbag squibs (R12/4, R12/5)	□ 23 ⇒ 4.0, 10.0
5	Left front seat belt buckle switch (S68/3)	□ 23 ⇒ 5.0
6	Right front seat belt buckle switch (S68/4)	□ 23 ⇒ 6.0
7	Front passenger airbag resistance	□ 23 ⇒ 7.0
8	Voltage supply circuit 15R	□ 23 ⇒ 1.0
9	SRS malfunction indicator lamp (A1e15) or time limit for DTC readout /erasing exceeded	□ 23 ⇒ 8.0
10 <sup>2)</sup>	SRS control module (N2/2)	N2/2 (SMS, Job No. 91-620)

<sup>1)</sup> Observe Preparation for Test, see □ 22.

<sup>2)</sup> DTC 10 indicates that the airbag deployment stage was activated in the control module. This DTC can not be erased.

**The control module must be replaced.**

### **IMPORTANT NOTE!**

Before replacing the SRS control module (N2/2) in cases of DTC 10 without an airbag deployment, reposition airbag harness ground connections to lowest terminal connection.

Note:

The ETR's are not included in the DTC readout, if DTC 3 and/or 4 can not be erased, see ETR Test □ 32 ⇒ 1.0 and 2.0 <sup>1)</sup>.